

# PAC Mega-Bore Pneumatic Self-Contained Chuck



## Application / Benefits

Suitable for large pipe machining  
Utilizes full spindle through hole

## Technical features

Self-contained air chuck with check valve  
Maintains pressure during power outage

## ACTUAL GRIPPING FORCE DIAGRAM

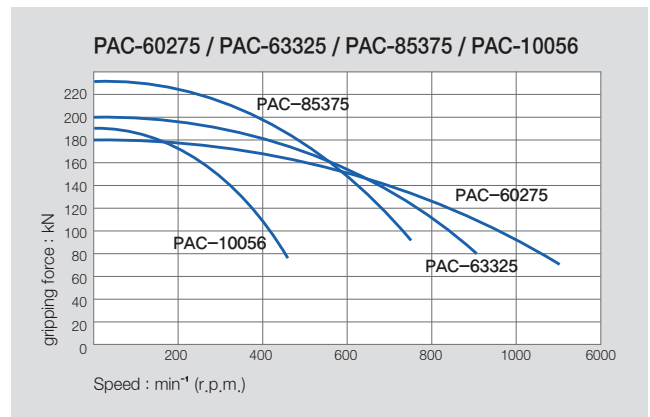
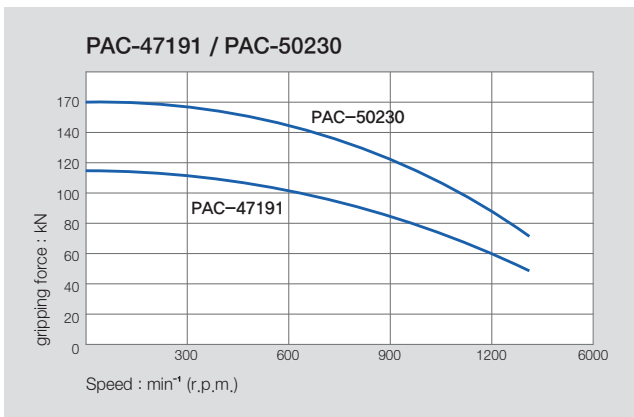

## SPECIFICATIONS

	PAC-47191	PAC-50230	PAC-60275	PAC-63325	PAC-85375	PAC-10056
Thru Hole Dia. [mm]	191	230	275	325	375	560
Jaw Stroke Dia. [mm]	20	25.4	25.4	25.4	25.4	25.4
Rapid	13	16.9	16.9	16.9	13.4	15
Clamp	7	8.5	8.5	8.5	12	10.4
Operating Pressure [MPa]	0.2~0.8	0.2~0.8	0.2~0.8	0.2~0.8	0.2~0.8	0.2~0.8
Clamping Force [kN]	115	170	180	200	230	190
Max. r.p.m. [min⁻¹]	1300	1300	1100	900	750	450
Weight [kg]	190	325	355	630	970	960
Moment of inertia [N · m²(kg · m²)]	9.8	16.1	20.6	35.1	105	157.6

Thru Hole Range :  $\varnothing 191 \sim \varnothing 560$   
 Clamping Range :  $\varnothing 80 \sim \varnothing 800$

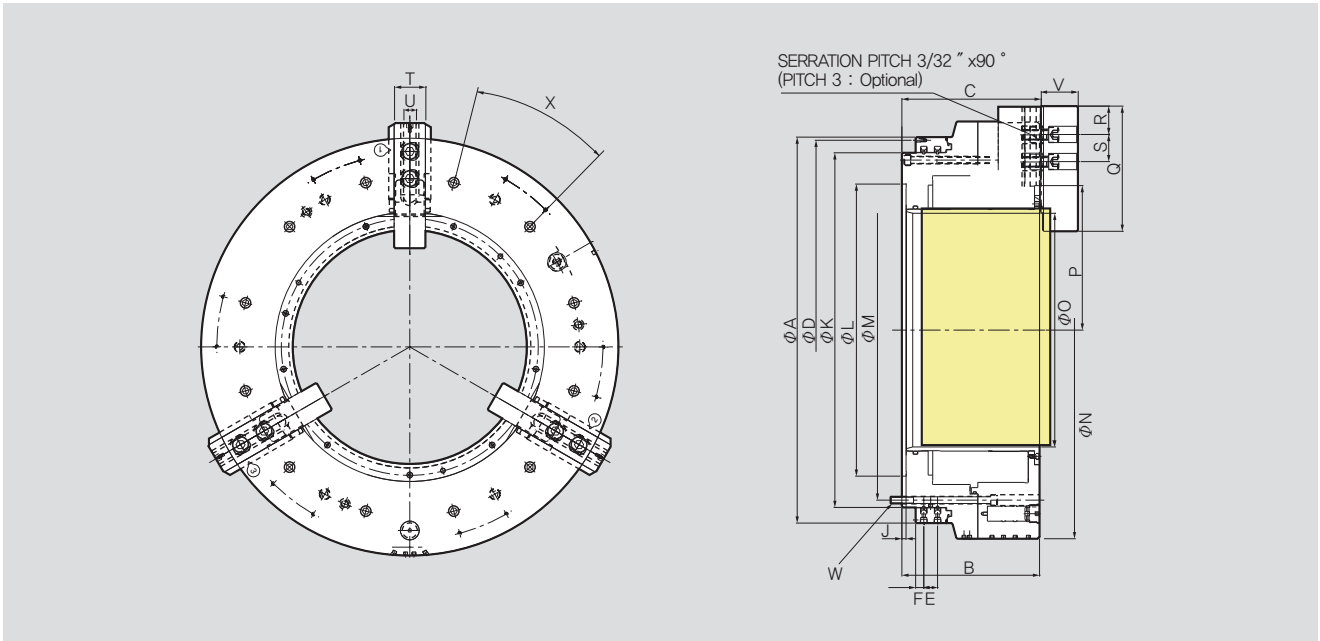

※ It is recommended to grease chucks at least twice a day in order to maximize longevity.

## DIMENSIONS

	PAC-47191	PAC-50230	PAC-60275	PAC-63325	PAC-85375	PAC-10056
ΦA	470	570	605	685	850	1000
B	238	280	280	305.5	352	330
C	240	282	284	329.5	356	334
ΦD	448	550	585	666	830	910
E	26	26	26	33	33	33
F	17	17	17	19	19.5	19.5
J	8	8	8	8	8	10
ΦK	400	500	535	610	775	850
ΦL(기준경)	310	415	450	510	700	700
ΦM	374	474	508	580	745	815
ΦN	470	570	605	685	850	1000
ΦO	191	230	275	325	375	560
P Max.	147	180.5	205.9	230.9	268	346.3
P Min.	127	156	180.5	205.5	268	321.1
Q	170	195	195	240	300	300
R	25	37	37	42	68	68
S	40	40	40	65	65	65
T	60	60	60	75	75	75
U	25.5	25.5	25.5	30	30	30
V	60	80	78	80	90	88
W	9-M12	12-M12	12-M12	12-M16	12-M16	12-M16
X	40°	30°	30°	30°	30°	30°